

SapphireTM

Air Purification System by American Ultraviolet Company



Healthier Air with the SapphireTM

Purify Your Home

With the Healing Power of Germicidal Ultraviolet Light

Indoors, the vast majority of airborne pathogens that cause illness thrive in the comforts of your home and continually recirculate through your HVAC system.

Now you can bring the power of Germicidal Ultraviolet Light inside to purify the air in your home and free your family of the most persistent diseases and allergens.

Ultraviolet energy in the germicidal wavelength of 254 nanometers is the most lethal to microorganisms. The UV disrupts the cell DNA, either destroying the cell completely or making it unable to reproduce. By installing the Sapphire™ in your recirculating air system, microbes are being constantly irradiated and eliminated from the air that you breathe.

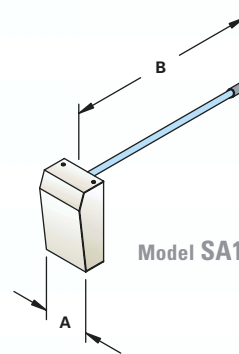
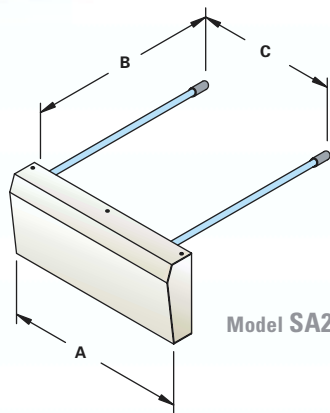

MODEL	A	B	C	LAMP	INTENSITY* @ 12"
SA1 - 14	4.25"	14.00"	N/A	GML405	710 uW/cm ²
SA1 - 16	4.25"	16.00"	N/A	GML430	840 uW/cm ²
SA2 - 14	14.00"	14.00"	12.00"	GML405	1420 uW/cm ²
SA2 - 16	14.00"	16.00"	12.00"	GML430	1680 uW/cm ²
SA2 - 24	14.00"	24.00"	12.00"	GML435	2580 uW/cm ²

* Intensity is measured in microwatts per square centimeter.



Turn on a Sapphire

American Ultraviolet Company—an innovator in the UV industry since 1960—introduces the Sapphire residential germicidal air purification system.

Installed by your local heating and cooling professional in your HVAC system, the Sapphire comes in contact with all the airborne bacteria, viruses, and other pathogens circulating throughout your house.

As air passes through the Sapphire's emissions, its UV light instantly kills any existing airborne microbes. While the Sapphire is working quietly in your ventilation system, you'll feel its healing power more every day as you enjoy a healthier breath of life inside your home.

The Sapphire is available in multiple configurations of single and dual lamp fixtures designed for both cooling coil irradiation, as well as return air duct mounting. Recent studies have shown the cooling coil and drain pan area to be a breeding ground for mold and mildew. Left unchecked, the infestation on the coil will continue to grow and release particles into the recirculating air of your home's forced-air system. Installing a Sapphire will eliminate this growth process and ensure a healthier air system.

Consult your
American Ultraviolet Company
representative for recommendations.

1-800-288-9288

Please visit us at
www.americanultraviolet.com
to review our complete product
line and receive further technical
information pertaining to UVC
for HVAC systems.

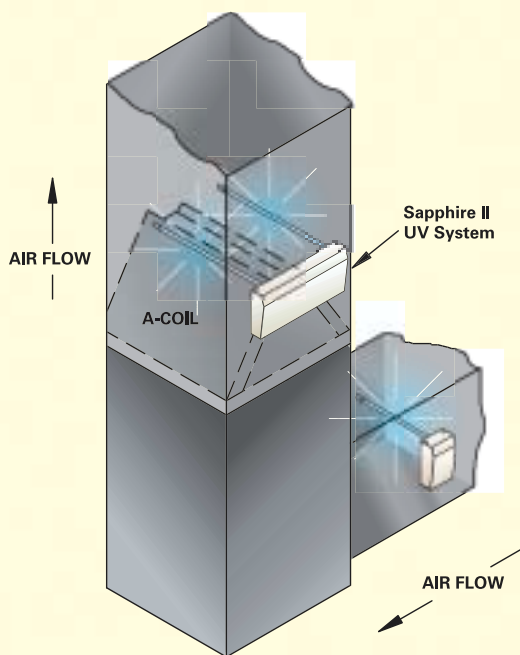

Depiction of an upblast cooling coil set up with a Sapphire Model SA2 mounted above the coil and a Sapphire Model SA1 mounted in the cool air return duct.

The Harsh Reality in Your Home

It's quite common—especially if you have children with developing immune systems or family members with asthma or allergies—that no matter how hard you work to keep your home clean, you can't seem to alleviate those recurring sinus, cold or flu symptoms.

That's because the bacteria, viruses, molds, fungi, and other harmful pathogens that pollute your household atmosphere cannot be eliminated with a spray bottle and dust rag. Nor can they be trapped by even your most trusted and sophisticated heating, air-conditioning or ionic air filtration systems.

According to the American Medical Association, contaminated indoor air causes or intensifies 50% of all illness. The fact is, to adequately protect your health and the health of your family, you need a germicidal air purification system installed in your house.



Molds like this can grow in the moist areas of your home's A/C unit and duct work, releasing airborne disease-causing spores that are unstoppable by modern air filtration systems.

Breathe Better, Live Better

Call American Ultraviolet Company about having a Sapphire™ installed in your home. We will assess your square footage requirements and recommend the proper placement and number of lamps to ensure complete, effective UV germicidal air purification that will have your whole family breathing more easily.

Installation is simple, and 24-hour operation is economical and virtually maintenance-free. In fact, changing the lamp(s) once a year is all that's required to ensure years of trouble-free service.

American Ultraviolet Company

1-800-288-9288

Fax: 765-483-9525

www.americanultraviolet.com

e-mail: mstines@americanultraviolet.com

